

Terminal definition

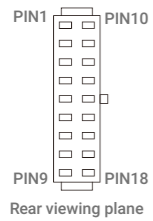

PIN	signal	PIN	signal
1	24V	10	GND
2	LOCK+	11	LOCK-
3	CANH	12	CANL
4	CANH	13	CANL
5	485A	14	485B
6	485A	15	485B
7	OUT1+	16	COMO
8	COMI	17	DI1
9	Empty	18	DI2

iWMC Integrated Servo Wheel Control Wiring Diagram

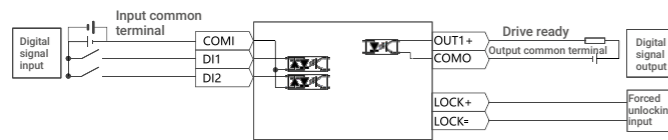

Wiring Diagram of Recommended Circuit for Forced Unlocking Brake

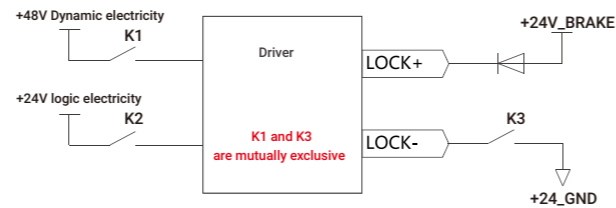

Note: The forced unlocking function needs to be used after the power supply of the servo wheel is cut off.

Power port

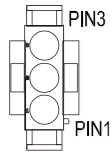

Pin number	Pin name	Pin function
3	DC-	The input end of the power supply of the driver must be connected
1	DC+	Input voltage: 24~60VDC

Brake resistance port

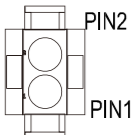

Pin number	Pin name	Pin function
1	RB+	External braking resistor input terminal
2	RB-	

iWMC Integrated Servo Wheel

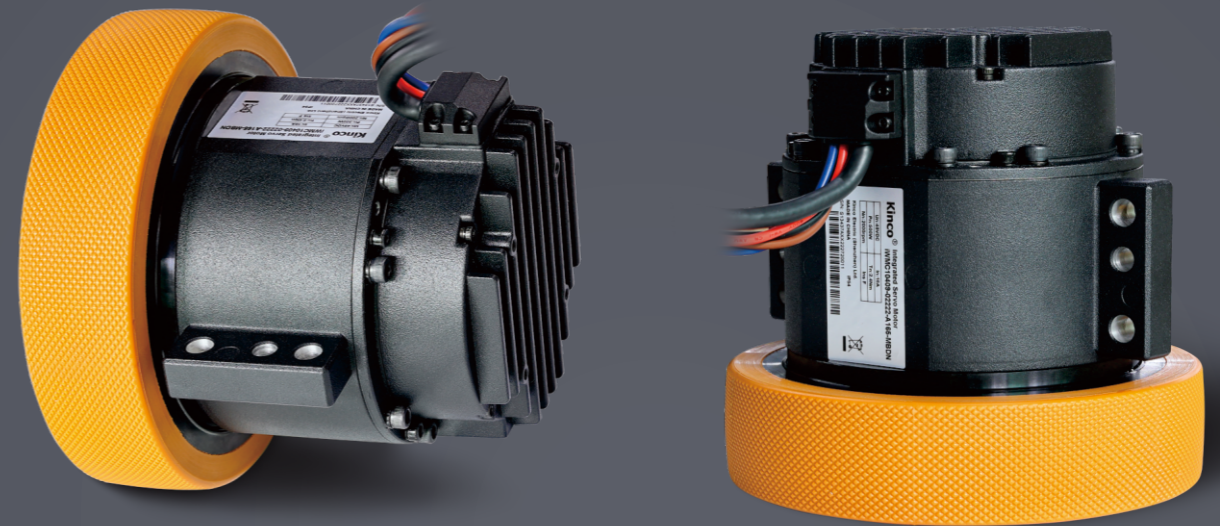

- ☑ Design of dual power supply for driver
- ☑ Support external forced unlocking
- ☑ Standard CANopen communication protocol
- ☑ The reducer has low back seam and high precision

Superiority

Highly integrated: The four main components of the driver, motor, gearhead, and wheel are highly integrated, resulting in a compact structure that facilitates downsizing;

High mounting accuracy: Supported mounting, simple and convenient mounting method, high mounting accuracy, and high control accuracy;

High reliability: The integrated module, with only external power supply and communication cables, is resistant to nickel-contacts and improves the stability and reliability of the entire system;

Compatible design & seamless switching: the communication and usage modes of the servo wheel products are no different from those of the standard Kinco products, allowing seamless switching;

Good maintainability: A single supplier for the integrated product facilitates the maintenance of the product at a later stage and reduces supply chain and after-sale costs.

Application Scenario

- Power Servo Wheel Module for Mobile Machines with Loads up to 600 kg
- Power Servo Wheel Module for Mobile Machines with Loads up to 1 T

iWMC Integrated Servo Wheel

■ Naming convention

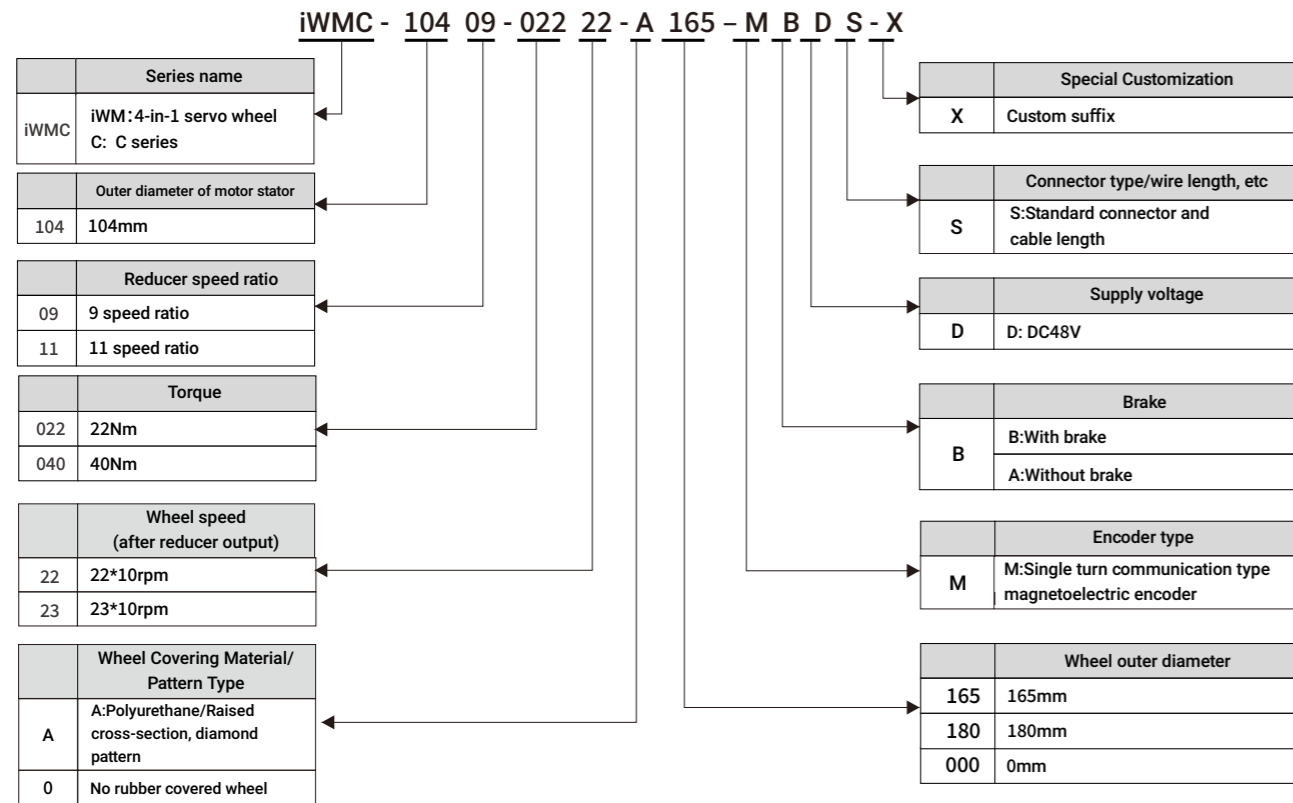

■ Product Parameters

iWMC Integrated Servo Wheel Model Number		iWMC10409-02222-A165-M■DS	iWMC10411-04023-A180-M■DS
Power	Power Supply	24VDC~60VDC	
	Logic Supply	24VDC	
Rated Linear Speed (m/s)		1.9	2.14
Rated Torque Tn(Nm)		21	40
Peak Torque Tn(Nm)		60	99
Tire Diameter (mm)		165	180
Tire Width(mm)		39.5	50
Tire Material		Polyurethane (optional)	
Tire Hardness Rating		85A	90A
Energy Consumption Braking		External braking resistor is required (depending on the operating conditions, mainly used for rapid starting and stopping)	
Energy Consumption Braking Voltage Absorption Point		DC63V ± 2V(Default, settable)	
Overvoltage alarm point		DC68V ± 2V	
Undervoltage alarm point		DC18V ± 2V	
Input Specifications		2 digital inputs / Common COM1 terminal / High level: 12.5-30VDC / Low level: 0-5VDC / Maximum frequency: 1KHz / Input impedance: 5KΩ.	
Output Specifications		1 digital output common COM0 terminal / Maximum output current: 100mA	
Brake		Built-in brake and control circuit	
Forced Unlock Interface		1-way forced unlock interface, only for use when there is no power input to the servo wheel	
RS485 Debug Port		Maximum support for 115.2Kbps baud rate	
CAN BUS		Maximum support for 1Mbps baud rate, CANopen protocol can be used to communicate with the controller	
Drive Current	Max. continuous output current (rms)	16A	26A
	Peak Current (PEAK)	100Ap(<2s)	100Ap(<2s)
Motor	Rated RPM nN(rpm)	2000	2500
	Rated Torque Tn(Nm)	2.4	4
	Brake Holding Torque T(Nm)	4	
Noise		<65dB	
Cooling Methods		Natural cooling & Body-assisted cooling	
Operating Environment	Operating Temperature	0~40°C	
	Storage Temperature	-20°C~60°C	
	Humidity (non-condensing)	90%RH below	
	Protection Level	IP54	
	Altitude	The rated working altitude is up to 1000m above sea level. For working altitudes above 1000m, a reduction of 1.5% is required for every 100 meters of rise in altitude, with a maximum working altitude of 2000 meters above sea level.	
	Atmospheric Pressure	86kpa~106kpa	

Note: ■ = A: Without brake B: With brake

iWMC Integrated Servo Wheel

■ iWMC10409-02222-A165-M■DS

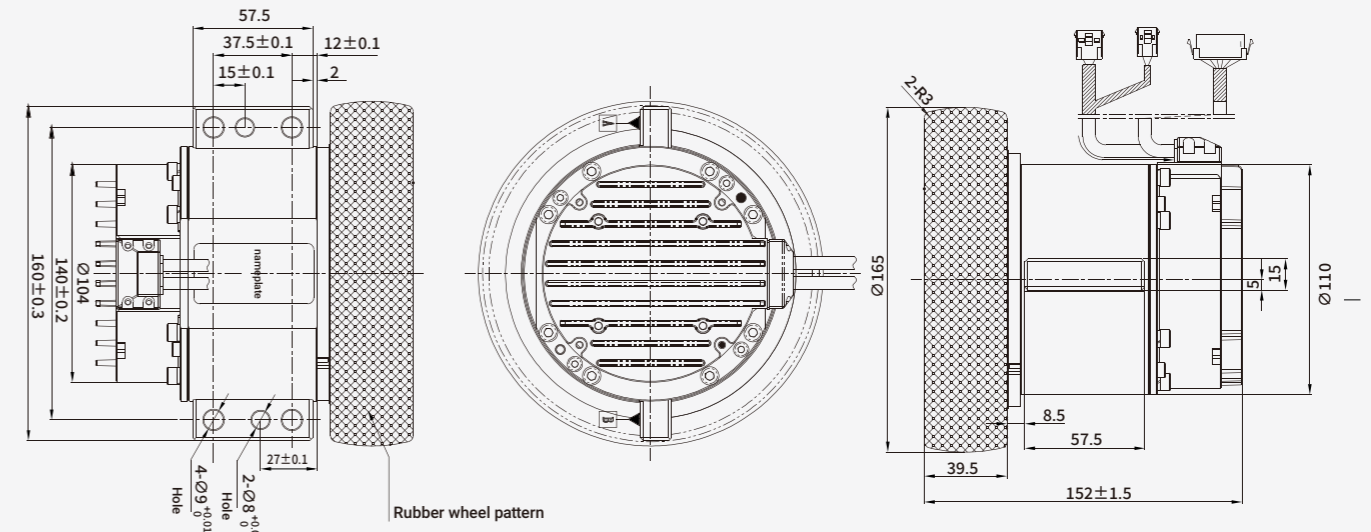

■ iWMC10411-04023-A180-M■DS

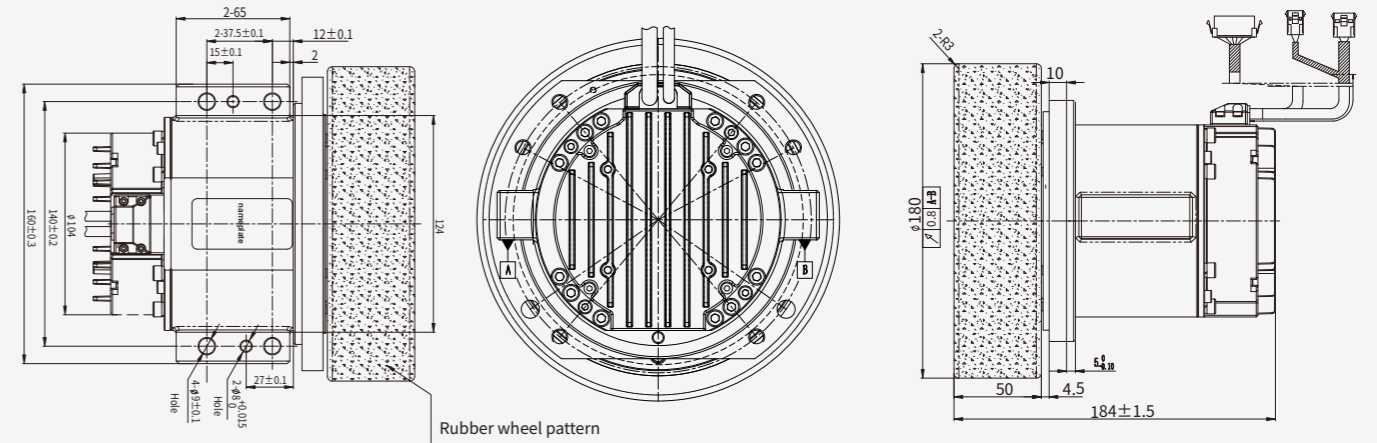

■ External Wiring Diagram

